

HEK GTP T 1500 Transport Platform



POWER SUPPLY REQUIREMENTS

Voltage: 240V, 3 Phase
 Frequency: 60 Hz
 Breaker Size: 50A

MACHINE SPECIFICATIONS

Platform Speed: 39 ft/min
 Maximum Height:
 Anchored: 394 ft
 Freestanding: 0 ft
 Anchor Distance: 20 ft - 26 ft
 Height of First Anchor: 10 ft - 13 ft
 Mast Height Above Top Anchor: 10 ft
 Standard Extension: N/A
 Motors (Vertical Travel): 2 x 4.0 kW
 Motors (Horizontal Travel): N/A
 Control Voltage: 24V
 Starting Current: 80A
 Running Current: 30A

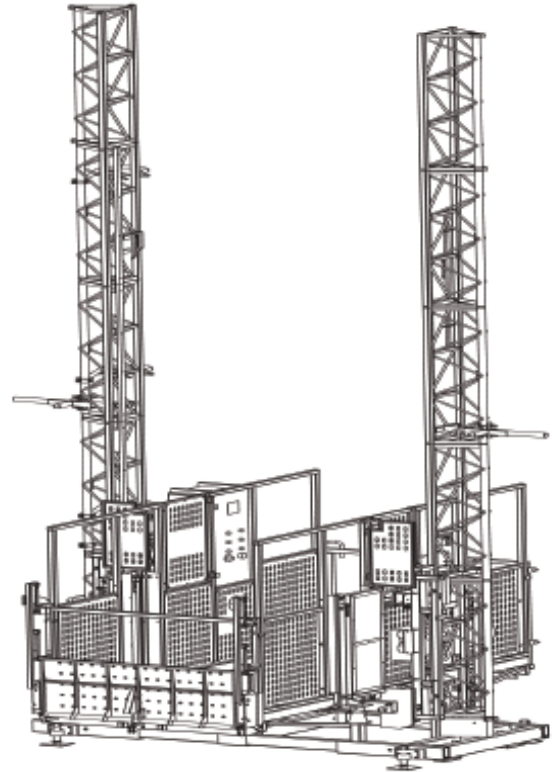

COMPONENT WEIGHTS

Base Machine:¹ 4365 lb
 Mast (4'-11"): 110 lb

¹ Weight of base machine includes 2 masts and 2 red top masts.

LIFTING CAPACITY

3300 Pounds

DIMENSIONS

A	10'-8 3/4"
B	10'-3 1/4"
C	7'-2 5/8"
D	9'-6 3/16"
E	5'-6 9/16"
F	4'-7 1/8"
G	5'-1 7/8"
H	11'-9"

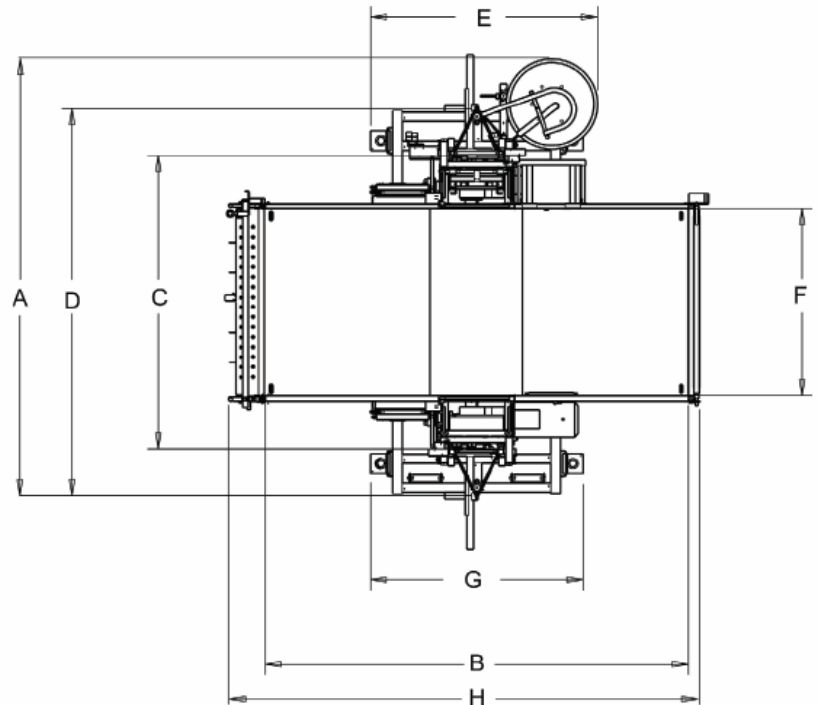

Alimak Hek, Inc. Construction Division

3414 Florence Circle, Suite 300 • Powder Springs, GA 30127
 Tel (800) 343-2449 • (770) 424-3232 • Fax (770) 439-4689
 www.alimakhek.com

8400 Villa Drive • Houston, TX 77061
 Tel (800) 345-0481 • (713) 640-8500 • Fax (713) 640-8519
 www.alimakhek.com

Data Sheet GTP T 1500 Rev. 7/07